

shaft shown in full
C.C.W. position

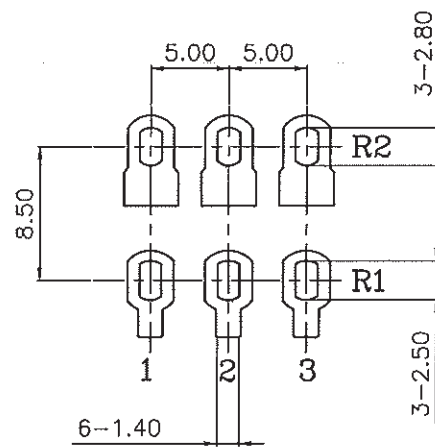

3					
2					
1					
NO	DATE	DESCRIPTION	DRAWING NO	R1610G-QB1-A	
TOLERANCE		SCALE	DRAWN BY	CHECK BY	APPROVED BY
less than 10±0.3		3/2			
above 10-30±0.5		DIMENSION			
above 30-100±1.0		m/m			

MODEL:R1610G-QB1-A***

阻值

Mechanical characteristics:機械的性能:

Item<項目>	Test methods<試驗方法>	Performance<性能>
Total rotational angle/travel 全迴轉角度/行程	Determined by measuring the rotational angle(travel) when the shaft(lever) is turned(moved) from the end position of terminal 1 to the end position of terminal 3. 軸(柄)置予 1 端最底部移往 3 端最底部之旋轉角度(移動行程).	300°±5°
Rotation torque 迴轉扭力	Determined by measuring the torque(operating force) necessary to turn(move) the shaft(lever). Unless otherwise specified, measurement shall be made at ambient temperature of 5 to 35°C, and the shaft rotational speed shall be 60° per second and the lever traveling speed 20mm per second. 測定扭力必須要旋轉軸或移動推柄, 周圍溫度在 5~35°C 時, 軸以每秒 60° 速度轉動, 推柄以每秒 20mm 速度滑動, 特殊品除外. <以扭力計或拉力計測得>	90±30 gf-cm
Shaft rotational stopper strength 軸的止迴轉強度	With the shaft(lever) placed at the end of terminal 1, a specified torsional moment(force) shall be applied in that direction for 10 seconds. Next, the shaft(lever) shall be placed at the end of terminal 3 and a specified torsional moment(force) shall be applied similarly, to check the operating part and other related sections for deformation, breakage, etc. 軸從 1 端移至止擋點或從 3 端移至止擋點 10 秒後, 直至破壞之力量. < 以扭力計測得>	7 kgf-cm
Push-pull strength 軸推拉強度	A specified force shall be applied in the axial direction of the shaft(lever) for 10 seconds to check the operating part and other sections for deformation, breakage, operating condition, etc. 以軸(柄)的軸線方向施加力量, 經 10 秒後, 核對部份動作之有無斷面變形、破損、等情況.	7 kgf

MODEL:R1610G-QB1-A***

阻值

Electrical characteristics:電氣的性能:

Item<項目>	Test methods<試驗方法>	Performance<性能>
Resistance taper 阻值線性	<p>With the shaft(lever) placed in the specified position, shall be determined by measuring the voltage between the specified terminals(between terminals 1 and 2 or between terminal 2 and 3) and calculating the percentage in reference to the voltage between terminals 1 and 3.</p> <p>軸(柄)在特別位置測定特別端子間的電壓(端子 1 至端子 2 之間或端子 2 至端子 3 之間)參考端子 1 到端子 3 之間的電壓計算的百分比.</p>	A
<p>Reference: Standard resistance tapers in reference to rotational angles(travel) are as shown below:</p> <p>參考:標準阻值曲線及旋轉角度(行程)表示如下:</p> <div style="text-align: center;"> </div>		
Total resistance 總阻值	<p>With the shaft(lever) placed at the end of terminal 1 or 3, shall be determined by measuring the resistance between the resistor terminals 1 and 3 unless otherwise specified.</p> <p>軸(柄)位置於端子 1 或 3 終端處,測定端子 1 到 3 的電阻值.</p>	<p>10K ~ 100KΩ</p>
Total resistance tolerance 總阻值容許差		±20%
Max. operating voltage 最高使用電壓	<p>Terminal 1 to 3 that can be applied to the maximum voltage.</p> <p>端子 1 到端子 3 所能承受最大電壓</p>	150V
Residual resistance 殘留阻值	<p>With the shaft (lever) placed at the end of terminal 1, shall be measured between the terminals 1 and 2. Next, with the shaft (lever) placed at the end of terminal 3, the resistance shall be measured between the terminals 2 and 3. If there are tapped terminals, the shaft(lever) shall be turned(moved) and the resulting minimum resistance between the tapped terminal and the terminal 2 shall be measured.</p> <p>軸(柄)轉到端子 1 最終位置,測定端子 1 2, 軸(柄)轉到端子 3 最終位置,測定端子 2 3,所得最小阻值即是.</p>	<p>250KΩ > R > 10KΩ</p> <p>20Ω max.</p> <p>10KΩ \geq R 10Ω max.</p>

MODEL:R1610G-QB1-A***

阻值

Item<項目>	Test methods<試驗方法>	Performance<性能>						
<p>Rated power 定格電力</p>	<p>The maximum value of electric power that can be applied continuously to the whole area of a resistor (between terminals 1 and 3) at the rated ambient temperature. Meanwhile, assuming that the rated ambient temperature of a carbon film resistor is 50°C, then the maximum power at an ambient temperature of 50~70°C can be obtained by multiplying the rated power by the rated power ratio determined from the derating curve shown below:</p> <p>周圍溫度相同,最大電力值能連續使用電阻完整面積(指端子 1 到端子 3 之間).</p> <p>此時,假設炭膜阻值周圍溫度比是 50°C, 最大電力值周圍溫度 50~70°C 可獲得定格電力比決定如下表示:</p> <div style="text-align: center;"> <p>定格電力的輕減曲線 Derating curve</p> <table border="1"> <caption>Derating Curve Data</caption> <thead> <tr> <th>Ambient temperature (°C)</th> <th>Rated power ratio (%)</th> </tr> </thead> <tbody> <tr> <td>50</td> <td>100</td> </tr> <tr> <td>70</td> <td>33</td> </tr> </tbody> </table> </div>	Ambient temperature (°C)	Rated power ratio (%)	50	100	70	33	<p>0.06W</p>
Ambient temperature (°C)	Rated power ratio (%)							
50	100							
70	33							
<p>Rotational/sliding noise 迴轉/滑動雜音</p>	<p>Measured by connecting the resistor to the amplifier having frequency characteristics specified in JIS C 6443, (if rated voltage is 20V or less, this voltage shall be applied) and by rotating (moving) the shaft (lever) at a speed of about 30 cycles per minute.</p> <p>依 JIS C 6443 測定,旋轉(移動)軸(柄)以每分鐘大約 30 次動作.<以雜音表測定>.</p>	<p>Less than 100mV</p>						
<p>Insulation resistance 絕緣抵抗</p>	<p>Measured with a megger by applying specified voltage to the specified locations.</p> <p>The undermentioned spots shall be tested unless otherwise specified. However, if the section concerned is so constructed as to conduct, that particular part shall not be tested.</p> <p>測定端子與端子間,端子與固定架間,所得電阻器基板之絕緣電阻.</p>	<p>More than 100MΩ at DC 500V</p>						

MODEL:R1610G-QB1-A***

阻值

Item<項目>	Test methods<試驗方法>	Performance<性能>
Gang error 相互偏差(同步)	With the shaft(lever) placed in the specified position, shall be determined by applying test voltage of 2 to 15V(sinewave RMS value) between the terminals 1 and 3 at 1,000±200Hz and measuring the voltage between the resistor terminal 2 and the specified terminal(terminal 1 or 3), and shall be calculated by the following equation.Meanwhile, unless otherwise specified, DC test voltage may be applied. Gang error=20 log * V2/V1 <用 DB 表測知>	-40 to 0dB dB ≤ 3 dB
Manual Soldering heat 手焊錫溫度	Bit temperature of soldering iron:300°C for less Application time of soldering iron: Within 3s 溫度 300°C 以下,時間 3 秒鐘以內。	Below 300°C, Less than 3 seconds.

Durability:耐久的性能:

Item<項目>	Test methods<試驗方法>	Performance<性能>
Rotational/sliding life 迴轉/滑動壽命	The shaft(lever) shall be turned at a speed of 600 cycles per hour(counting 1 reciprocating motion as 1 cycle) and 5,000~8,000 cycles a day over 90% of the effective rotational angle(total travel).Unless otherwise specified, the following requirements shall be met after the test is completed: Variation in total resistance: ±15% Slider noise: less than 150mV 在無負荷情況下,軸(柄)以每小時 600 次的速度(有效來回 1 遍稱為 1 次),有效移動距離達 90%以上,每日 5,000~8,000 次的使用次數測試, 全阻變化:±15%. 滑動雜音:低於 150mV.	15,000 cycles (15,000 次)

REMARK: 備註:	PREPARED BY	REVIEWED BY	APPROVED BY
	