

Revision: 03

# Approval Sheet

CUSTOMER: AC48





CUSTOMER MODEL NO.: \_\_\_\_\_

MODEL NO.: SPS1201PC-T

PART NO.: @3A-101WX12-048

DESCRIPTION: Switching Power Supply

DATE: 2011-12-12

PREPARED	DESIGNED	CHECKED	APPROVED
			

APPROVAL DATE:

CUSTOMER APPROVAL		





## 1 Product Characteristics:

### 1.1 General Description

Model SPS1201PC-T is a universal switching-mode power supply, operating at input voltage 90VAC to 255VAC and output voltage of 12VDC with 1.0A DC load

### 1.2 Electric Characteristics

#### 1.2.1 Input

No	ITEM	SPECIFICATION
1.	Rated input Voltage	AC100V-240V
	Vibration input Voltage Range	AC90V-255V
2.	Frequency Rated	50-60Hz
	Frequency Vibration	47-63Hz
3.	Input Rated Current	300mA RMS Max
	Inrush Current	25A Max .at 115vac cool start
		50A Max .at 230vac cool start
4.	Leakage current	0.25mA
5.	Efficiency	65% Min.

FILE NO.: EN-RDS-J591

FILE: SPS1201PC-T

SHEET: 02

**1.2.2 Output:**

No	ITEM	SPECIFICATION
1.	output Voltage	12VDC
2.	output max. current	1.0A
3.	output min. Current	0A
4.	Line regulation	± 1%
5.	Output voltage tolerance	± 5%
6.	Over voltage protection	The output voltage shall be clamped by internal protection zener
7.	Short circuit protection	Output shut down and auto restart
8.	Ripple Voltage (L.F.)	150mV (p-p) (100V-240VAC at full load)

**1.2.3 HI-POT SPECIFICATION**

Input to output : 3000VAC 10mA 1 minute.

**1.2.4 Insulation resistance:**

Input to output: 500vdc to test the input to output resistance not be less 100M ohm

**1.2.5 Safety approved:**

Type(Marking)	Country/Region	Standard
PSE	Japan	Safety : 電気用品の技術上の基準を定める省令第1項別表第八1及び2 (102)
UL/CUL	USA/Canda	Safety : UL 60950-1
		Safety : CSA C22.2 No 60950-1-07
FCC	USA	EMI : FCC Part 15, SubpartB , Class B

**1.2.6 PB-free standard: RoHS Compliant**

### 1.3 Mechanical Characteristics

1.3.1 AC plug: Direct plug-In UL Type.

1.3.2 DC cord:

(1) Bending test: Life 1000 times 100% guarantee. Swings 120 from

Left to right loading weight 200g , 40 cycle/minute.

(2) Pull test : DC cord and plug ,weight 6kg for 1 minute.

1.3.3 Cord length and output plug: See Reference Att.4

1.3.4 Weight : 112 g

1.3.5 Case Size: (L)60 X (W) 44 X (H) 25mm

1.3.6 Normal operating temperature and humidity

1.3.7 Temperature

Operating: 0°C to 40°C

Storage : -10°C to 70°C

1.3.8 Humidity

Operating : 20% to 80%.

Storage: 10% to 90%

1.3.9 CASE PIN : With Tracking Pin

**2.Attachment:**

- (Att.1) Label**
- (Att.2) Outdrawing**
- (Att.3) Package**
- (Att.3.1) Package flow chart**
- (Att.4) DC cord drawing**
- (Att.5) Electrical test report**

Att.1

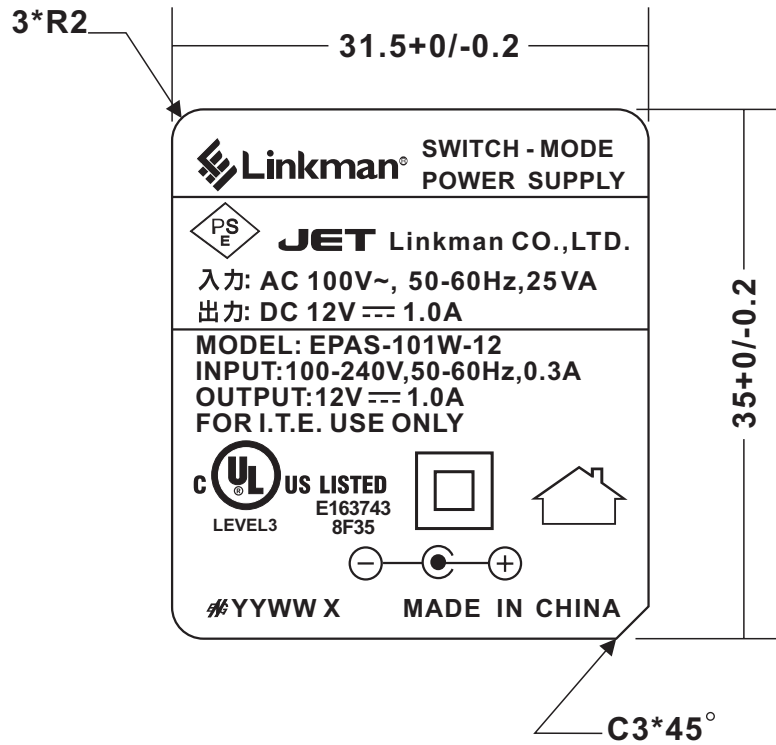

UNIT: mm

YYWW X YY:YEAR WW:WEEK X=S or A(S:FU YONG A:DONG GUAN)

ALUMINUM NAMEPLATE: ○ BLACK WORD ON SILVER BASE(銀底黑字)  
(鋁板)

○ SILVER WORD ON BLACK BASE(黑底銀字)

METALIZED POLYESTER: ○ BLACK WORD ON SILVER BASE(銀底黑字)  
(消銀龍) ● SILVER WORD ON BLACK BASE(黑底銀字)

TOLERANCE				

**@3A-101WX12-048**

DESIGNED	CHECKED	APPROVED		TITLE	DATE
Tanll	Liujin	LNB		UNITS	LABEL
			mm	DRAWING No.	
			SCALE	@N20-AC48A0-A04	
			2:1	DRAWING NAME	REVISION
				1002	02



Att.2

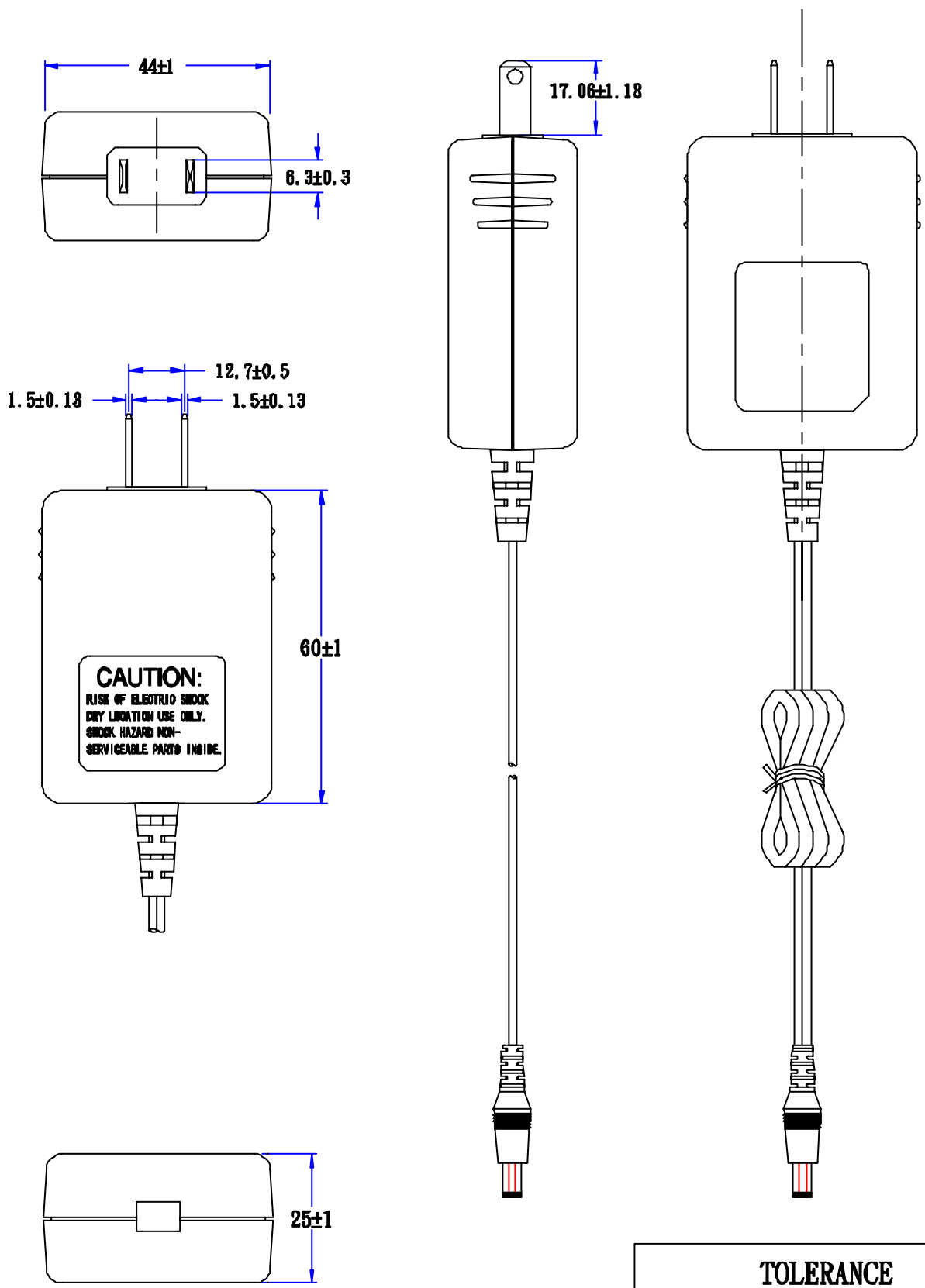

TOLERANCE				

DESIGNED	CHECKED	APPROVED		TITLE	DATE
<i>Hump</i>	<i>Zhoujg</i>	<i>Bill</i>		UNITS	OUTDRAWING
			SCALE	DRAWING No.	06/12/16
				SPS1201PC-T	
				DRAWING NAME	REVISION
				100201	01

Att.3

**CARTON SIZE:375\*368\*225mm**

Q'TY: 80PCS(20\*4)

數量 80PCS(20\*4)

N.W: 8.96KGS

G.W: 9.76KGS

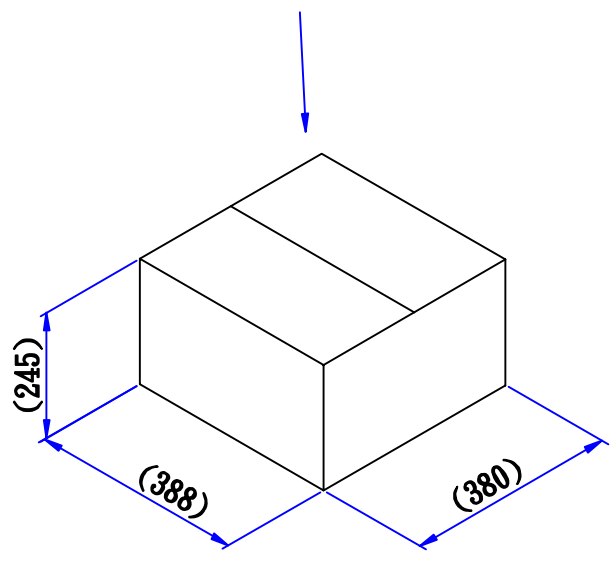
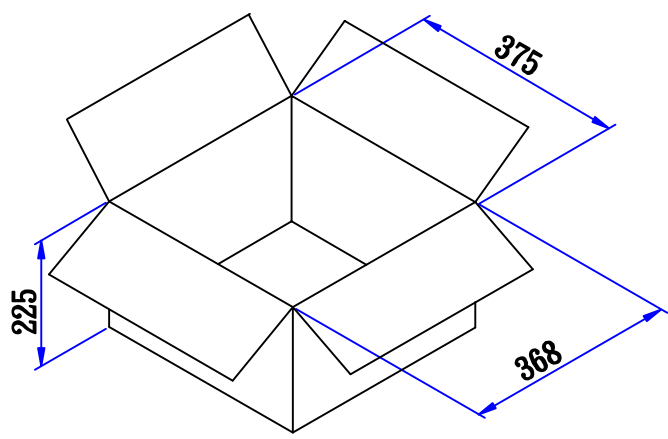

The tolerance of the internal dimensions of the carton is +7/-0  
 紙箱外度尺寸公差為：+7/-0

TOLERANCE				

DESIGNED	CHECKED	APPROVED		TITLE	DATE
<i>Hump</i>	<i>Zhoujg</i>	<i>Bill</i>		PACKAGE	06/12/16
			UNITS	DRAWING No.	REVISION
			SCALE	P36-2040-H-50	
				DRAWING NAME	01
				36-2040-H-50	

Att.3.1

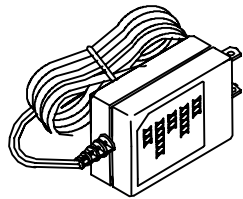

← Product

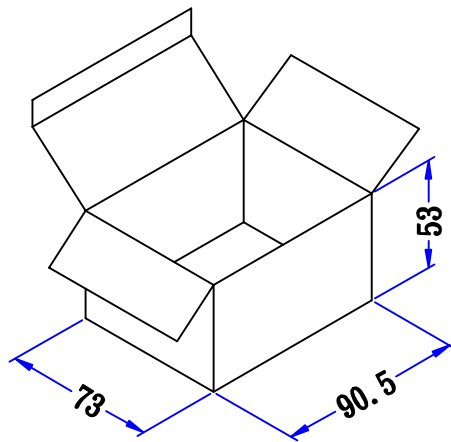

← WHITE BOX:36#

The tolerance of the external dimensions of the white box is  $\pm 1$   
 小禮盒外度尺寸公差為 $\pm 1$

TOLERANCE				

DESIGNED	CHECKED	APPROVED			TITLE	DATE
<i>Hump</i>	<i>Zhoujg</i>	<i>Bill</i>	UNITS	mm	<b>PACKAGE FLOW CHART</b>	
			SCALE		DRAWING No. SPS1201PC-T	06/12/16
					DRAWING NAME <b>36#</b>	REVISION <b>01</b>

Att.4

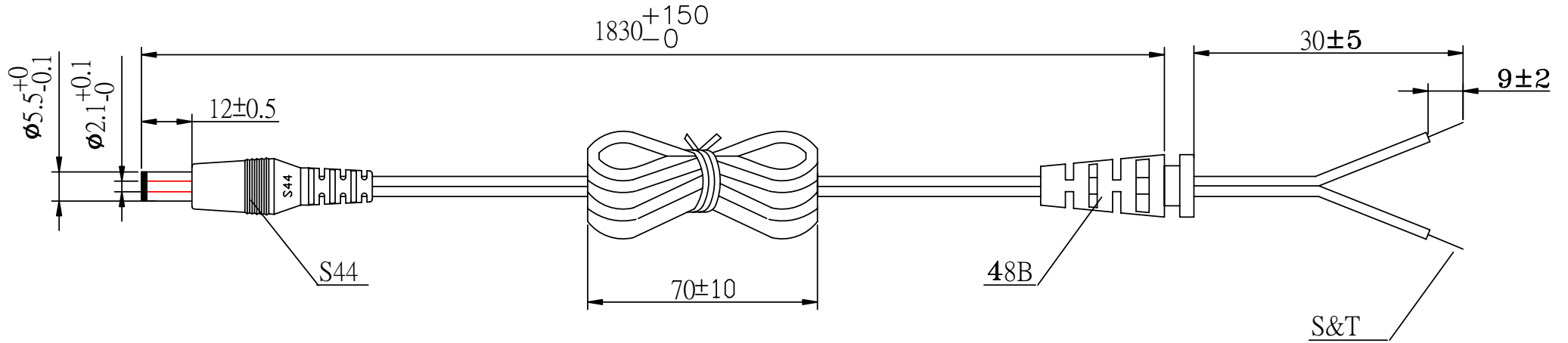

#20AWG X2C UL2468

HAVE ON WORD WIRE IN OUTER, NO WORD WIRE IN INNER

OD:  $\varnothing 1.9 \times 3.8$

TOLERANCE				

搖擺測試 VIBRATION TEST	a. $\pm 60^\circ$
	b. 吊重200g WEIGHT 200g
	c. 40回/分 40 ROUND/MINUTE
	d. 1000次/最少 OVER 1000 COUNT MIN

DESIGNED	CHECKED	APPROVED		
<i>Hump</i>	<i>Zhoujg</i>	<i>Bill</i>	UNITS	mm
			SCALE	

TITLE	DC CORD	DATE	
DRAWING No.	<b>SPS1201PC-T</b>		06/12/16
DRAWING NAME	31-48BS44-03B-00	REVISION	01